

A Capacitive Model of Water Salinity Wireless

by Suryono Suryono

Submission date: 18-Jun-2019 02:54PM (UTC+0700)

Submission ID: 1144853615

File name: 4_A_Capacitive_Model_of_Water_Salinity_Wireless.pdf (594.03K)

Word count: 2290

Character count: 12215

A Capacitive Model of Water Salinity Wireless Sensor System Based on WIFI-Microcontroller

1 Suryono Suryono
Department of Physics
Diponegoro University
Semarang, Indonesia
suryono@fisika.undip.ac.id

1 Supto Purnomo Putro
Department of Biology
Diponegoro University
Semarang, Indonesia
saptoputro@undip.ac.id

1 Widowati Widowati
Department of Mathematics
Diponegoro University
Semarang, Indonesia
widowatimath@undip.ac.id

1 Sunarno Sunarno
Department of Biology
Diponegoro University
Semarang, Indonesia
soena17@yahoo.com

Abstract - Monitoring for water salinity is very important in many industries, especially fishery and farming. Therefore, it is necessary to build a wireless water salinity sensor system capable of tackling obstacles in the field. This research proposes a low-cost wireless water salinity sensor system using parallel capacitive plate model. Capacitance effect that is proportional to salinity value is transformed into digital pulses using a circuit of an a-stable multivibrator. Frequency of these pulses is counted using a WIFI-microcontroller and inverse transform is carried out according to the relationship characteristics of salinity and frequency. Water Salinity data acquired by the WIFI-microcontroller are then transmitted to the Control Station Unit (CSU) via gateway WIFI. Testing results show maximum coverage range of 30 meters to the gateway. Nonetheless, the use gateway WIFI can increase the coverage range of this wireless water salinity sensor. Calibration tests also indicate an error of 2.3% in water salinity measurement by the instrument developed here.

Keywords — water salinity; capacitive; pulses; characteristics; error

I. INTRODUCTION

Salinity measurement in waters is very important to know the content of salt suspended in those waters. Salinity reflects the basic chemistry of water. The amount of acid-based chemical substance suspended in waters indicates the environmental quality and the biology in the waters. Salinity measurement is also very necessary for the success of aqua culture and farming [1]. Changes in salinity affect the osmosis pressure that is very much related to cell metabolism. Changes in salinity determine the characteristics of aquatic organisms, especially the plankton which is sensitive to changing environmental parameters. Salinity measurement is very important in the culture of all kinds of farming produce. Examples of these include wheat, in which soil salinity determines the growth and quality of this particular plant [2].

Salinity of a region is affected by many environmental factors such as topography, rainfall, tide, evaporation, and precipitation. Those factors should be measured by a device that works in situ, online, and in real-time. Salinity measurement is in many cases involving wide coverage area, as can be found for fishery and farming. The area to be covered may extend tens or even hundreds of kilometers [3]. Therefore, a measurement model that employs wireless sensor system technology is required. This is because manual measurement often comes with major errors as salinity changes with time [4].

There are many salinity model sensors already available in the market. Take for example the conductive and magnetic model, and recently, there is a salinity sensor model that works optically [5, 6]. Those sensor models do have advantages but they also come with disadvantages such as being operated manually or requiring expensive electronic instrument. Acquired data from salinity sensors sent to a communication network is very necessary to provide ease in processing and interpretation. This will save the hustle of going to the field for manual measurement that in turn will save cost. Acquired data can simply be directly transferred via data network [7].

This research proposes a capacitive water salinity sensor model that works on WIFI network. This sensor does not ionize the medium and does not require expensive investment to materialize. Salinity of the capacitive model sensor considers the medium measured only as a dielectric material. Its means that the circuit does not require a large current to know the level of salinity no ionization reaction occurs on the measured medium. Therefore, the length of time of salinity measurement in the media by such method has no significant effect. Less expensive investment is made possible with the help of microcontroller that reduces production costs. Nowadays, there has been integrated system between microcontroller and the WIFI that will lead to its effective and efficient performance. The use of microcontroller as measurement and processing basis saves costs up to 50% [8].

II. SYSTEM REALIZATION

This research explains the design and realization of capacitive model water salinity sensor and acquired data communication system with WIFI network using the system on chip (SOC) WIFI-microcontroller technology. The system developed here consists of two instruments; a Remote Terminal Unit (RTU) placed in measurement site, and another Control Terminal Unit (CTU) located at the monitoring station. A

diagram showing the water salinity sensor system that uses SOC WIFI-microcontroller technology is shown in Fig. 1.

In this system, capacitance is physically oriented toward changes in output values of both electrodes. That effect takes place when electrolysis fluid due to the interaction of electrons with electrodes does not affect measurement result. Resulting capacitance is only correlated to the permittivity of fluid dielectric that itself is correlated to water salinity value.

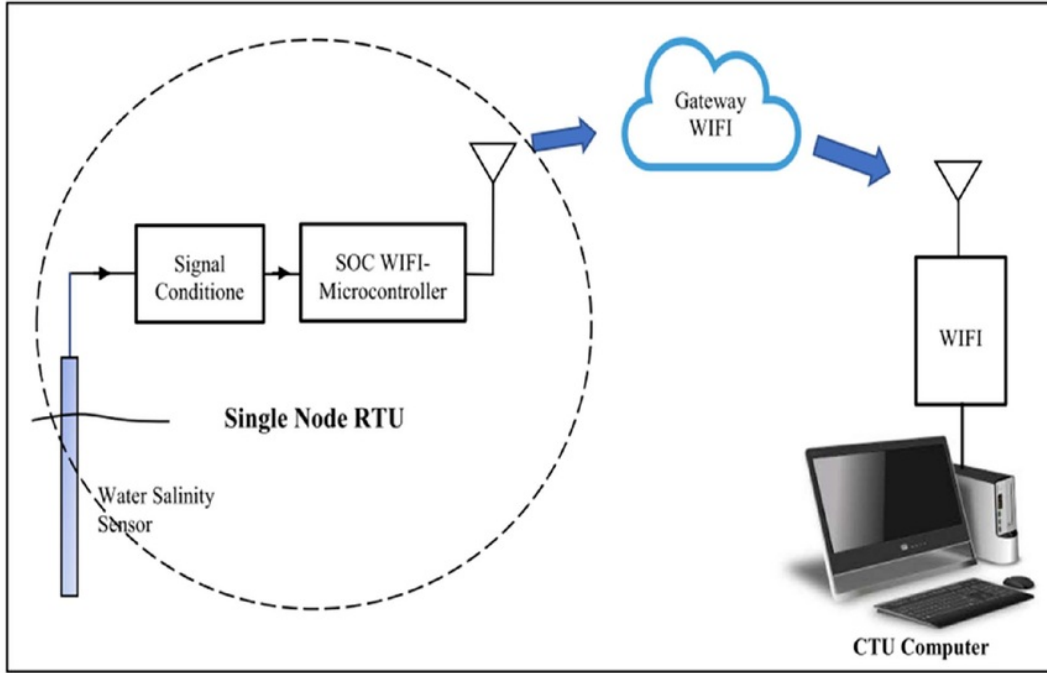

Fig. 1. The water salinity wireless sensor system diagram.

Capacitance equals salinity. Hence, a signal conditioning circuit that changes capacitance into electrical values to be acquired, quantified, and transmitted is required. In this research, water salinity sensor is made of two galvanic plates separated by the fluid dielectric to be measured. Spacing between the two plates is fixed and is able to contain charge flow from one plate to the other. Capacitance of those parallel plates is given by the following formula:

$$C = \frac{A\epsilon}{d} \quad (1)$$

In that equation, A is the area of the plate, d is the distance between the plates, and ϵ is the dielectric material permittivity. When current is applied, Gauss law applies, in that potential difference between two opposing charges will merge at each electrode. Conductivity value correlates with ϵ . Hence,

measuring C will lead to the conductivity value of the fluid tested. In order to obtain conductivity value an oscillator circuit is built, with the frequency determined by C. The output frequency of this oscillator can be read by WIFI-microcontroller and will be transmitted via that WIFI network. The circuit of this sensor system is depicted in Fig. 2.

Sensor made of two parallel plates results in C_s capacitance. The IC555 oscillator generates square waves with magnitude determined by R1, R2 and C1 and C_s . This means that frequency depends on C, which is related to ϵ and salinity. The output sensor frequency of this circuit is given by the following formula:

$$f_o = \frac{1.44}{(R_1 + 2R_2)(C_1 + C_s)} \quad (2)$$

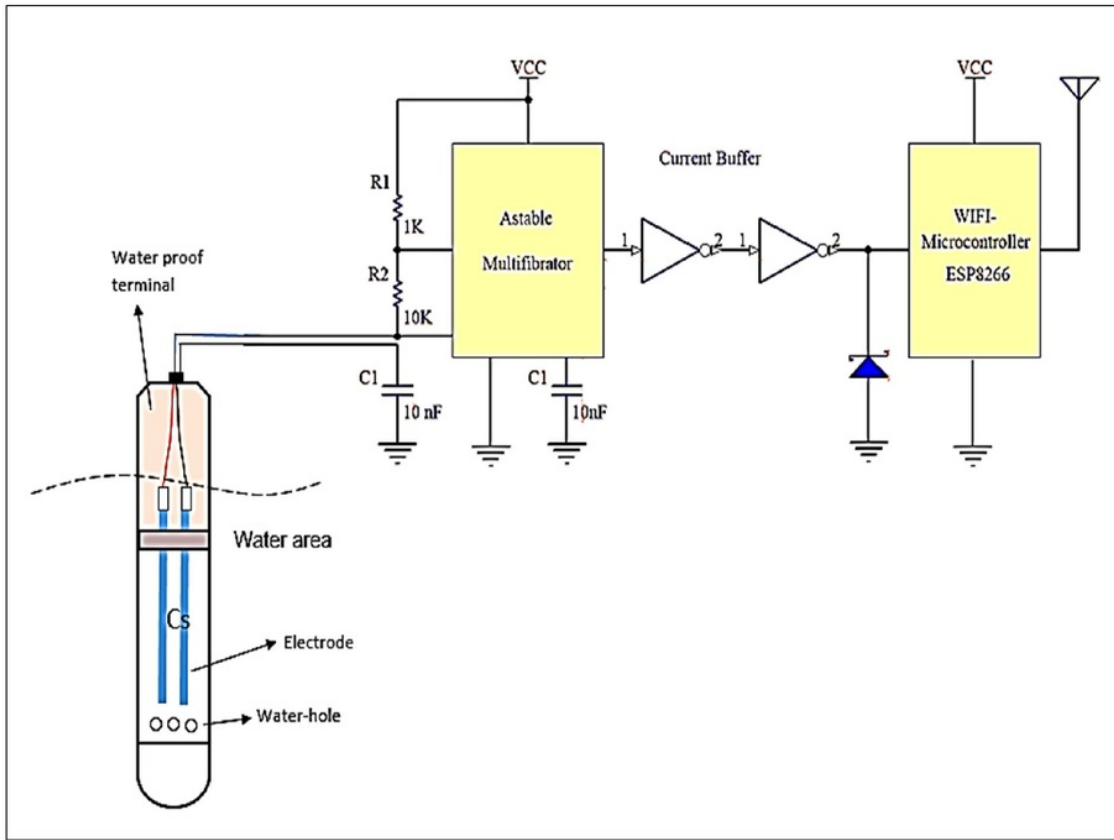

Fig. 2 The circuit of water salinity wireless sensor system with capacity model.

The current in that circuit is amplified by the NOT gate and the voltage is cut to 3.3 V by the diode. Those two measures are necessary to match the input voltage of the WIFI-microcontroller pin. An ESP8266 WIFI-microcontroller is used in this research to acquire frequency data and convert it to salinity unit. These data are then sent to the control computer of the terminal unit using gateway WIFI. Setting of IP address for that network is also required to make it work in one class with the IP address of the ESP8266 WIFI-microcontroller, the gateway WIFI, the computer WIFI and the computer CTU. The IP address configuration used in that wireless sensor system is shown in Table I.

IP address set up of the ESP8266 WIFI-microcontroller requires the code in C language that is downloaded onto the microcontroller chip. Meanwhile, gateway IP address is set

with a firmware, and the RTU computer IP address is set via the control panel setting. In this research, data acquisition system at the RTU computer is built with TCP/IP client socket programming. IP address of data acquisition at the RTU computer is targeted on the ESP8266 WIFI-microcontroller IP address. Acquired data that are saved in the database are data of time and salinity.

III. RESULT AND DISCUSSION

This research has successfully built water salinity sensor, data acquisition system, and data transmission via WIFI network. The system was tested by characterizing the sensor by setting output frequency of an astable multivibrator circuit against water salinity. Each variation of salinity value was measured using standard water salinity measurement device.

TABLE I. IP ADDRESS CONFIGURATION OF THE WIRELESS SENSOR SYSTEM

Address/Hardware	ESP8266 Sensor Node	Gateway WIFI	Computer WIFI	RTU Computer
IP Address	192.168.1.1	192.168.1.2	192.168.1.3	192.168.1.4
Subnet	255.255.255.255	255.255.255.255	255.255.255.255	255.255.255.255
Port	5001	-	-	5000

Results of sensor characterization are given in a graph shown in Fig. 3. Characterization results were then plotted on a graph and curve fitting was carried out in order to obtain a formula that relates salinity value and oscillator frequency. The results in a curve fitting equation of $y = -4E-07x^4 + 0.0015x^3 - 2.1542x^2 + 1330.1x - 306649$. It can be seen that the relationship of salinity and frequency is a 4-order polynomial equation.

This equation is used as the foundation for inverse transform programming on the IC of WIFI-microcontroller ESP8266 WIFI-microcontroller. Results of inverse transform programming are values of water salinity taken from output

frequency values that has been inserted into the curve fitting equation. Ideally, results of inverse transform should match the readings of standard measurement devices.

At the Control Station Unit (CSU), readings of water salinity measurement results are carried out with the help of a computer connected to the WIFI network with a gateway and are set at an IP address of the same class in the network. Sensor reading at the Remote Terminal Unit (RTU) is conducted with the help of TCP/IP client-server socket programming. Results of these sensor readings are displayed as numeric, graphs, and are saved in the database.

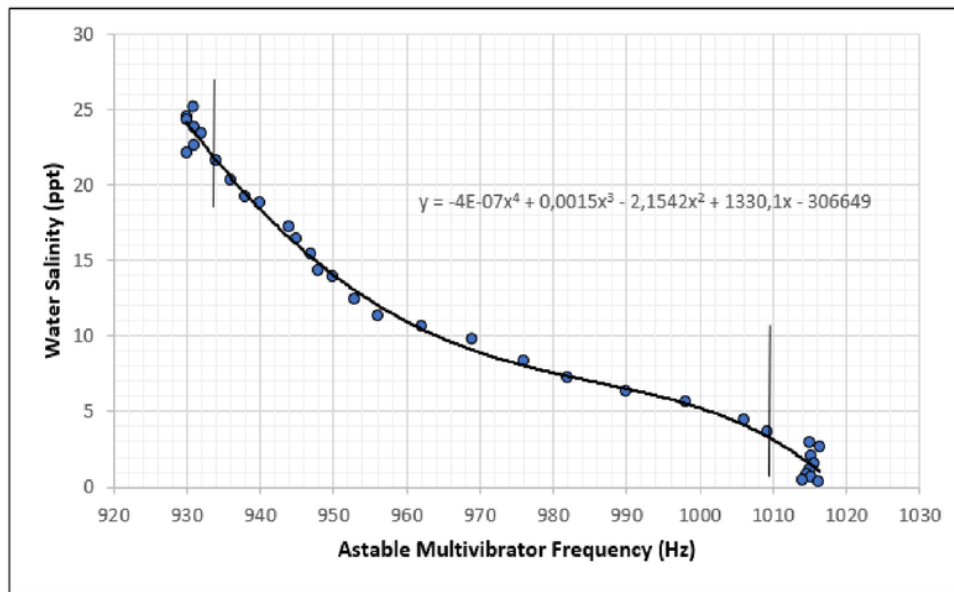

Fig. 3. Results of astable multivibrator – water salinity sensor characterization.

This research tested the effect of RTU distance to the gateway WIFI. This test was meant to figure out the range of WIFI-microcontroller in transmitting data to the WIFI gateway. Testing was carried out by measuring water salinity at the RTU and comparing the results with water salinity values at the CSU. Further testing involved measuring the distance and comparing water salinity concentration values at the RTU and CSU. Results of testing for RTU range are given in Table II. It is known that the maximum coverage range of the RTU is 30 meters. However, the use of gateway may extend that coverage range to the CSU. The use of gateway WIFI of bigger power can also increase coverage range up to tens and even hundreds of kilometers. The final and most important test in building an instrument is calibration. Calibration for this research was carried out by comparing values gained from standard

measurement devices with those of the sensor system built. Results of sensor calibration are given in a graph shown in Fig. 4. The graph shows instrument error of 2.3% against standard values.

IV. CONCLUSION

A salinity sensor can be built by harnessing the property of capacitance. Capacitance correlates with capacitance value triggered by sensor that data acquisition can be conducted by making an a-stable multivibrator. A system on chip (SOC) WIFI-microcontroller can be programmed as a counter by making a counting program for number of pulse per second from mono-stable multivibrator output entering the pin of the WIFI-microcontroller. Results of curve fitting characterization show that the relationship between salinity and frequency is in

the third order equation. A WIFI-microcontroller can perform inverse transform and send data to the Remote Terminal Unit (RTU) via a gateway WIFI. Testing results show maximum coverage range of 30 meters to the gateway. Nonetheless, the

use gateway WIFI can increase the coverage range of this wireless salinity sensor. Calibration tests also indicate an error of 2.3% in salinity measurement by the instrument developed here.

TABLE II. RESULTS OF TESTING FOR RTU TRANSMISSION TO GATEWAY

No.	Distance (m)	Water Salinity at RTU (ppt)	Water Salinity at CSU (ppt)
1	5	19.1	19.1
2	10	18.2	18.2
3	15	20.5	20.5
4	20	18.3	18.3
5	25	19.6	19.6
6	30	18.5	18.5
7	35	17.9	-
8	40	18.8	-
9	45	19.2	-
10	50	19.4	-

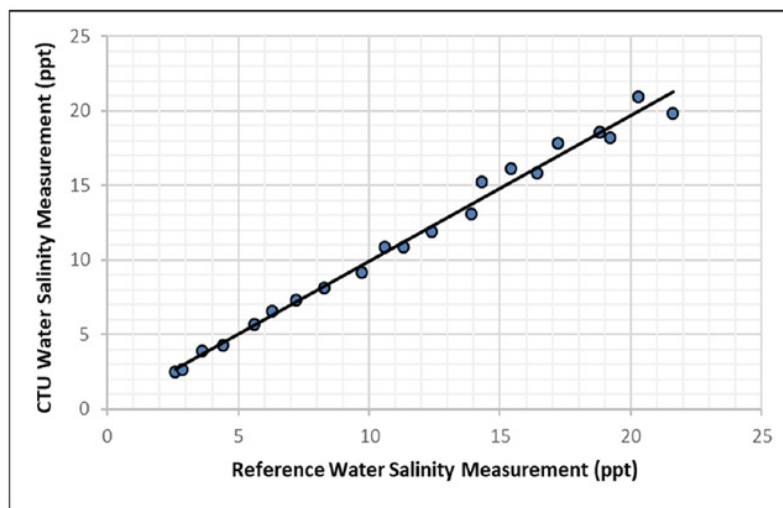

Fig. 4. Calibration results of water salinity wireless sensor system.

REFERENCES

[1] J. Wang and B. Chen, "Experimental research of optical fiber sensor for salinity measurement", *J. Sensors and Actuators A: Physical*, Vol. 184, pp. 53-56, 2012.

[2] R. Talebnejad and A.R. Sepaskhah, "Effect of different saline groundwater depths and irrigation water salinities on yield and water use of quinoa in lysimeter", *J. Agriculture and Water Manajemen*", Vol. 148, pp. 177-188, 2015.

[3] B. Kahlaoui, M. Hachicha, E. Mistle, F. Fidalgo and J. Teixeira, "Physiological and biochemical responses to the exogenous application of proline of tomato plants irrigated with saline water", *J. of the Saudi Society of Agricultural Sciences*, Vol. 17, pp. 17 – 23, 2018.

[4] I. Hussain, M. Das, K.U.Ahamad and P. Nath, "Water salinity detection using a smartphone", *J. Sensors and Actuators B: Physical*, Vol. 239, pp. 1042-1050.

[5] L. Parra, S. Sendra, J. Lloret and I. Bosch, "Development of a Conductivity Sensor for Monitoring Groundwater Resources to Optimize Water Management in Smart City Environments", *J. Sensors*, Vol. 15, pp. 20990-21015, 2015.

[6] H.A. Rahman, S.W. Harun, M. Yasin and H. Ahmad, "Fiber optic salinity sensor using beam-through technique", *J. Optic*, Vol. 124, pp. 679-681, 2013.

[7] T. Fukatsu, T. Kiura, and M. Hirafuji, "A web-based sensor network system with distributed data processing approach via web application", *J. Computer Standards & Interfaces*, Vol. 33, pp. 565–573, 2011.

A Capacitive Model of Water Salinity Wireless

ORIGINALITY REPORT

1 %	0 %	1 %	0 %
SIMILARITY INDEX	INTERNET SOURCES	PUBLICATIONS	STUDENT PAPERS

PRIMARY SOURCES

1	Ali Khumaeni, Zener Sukra Lie, Wahyu Setiabudi, Koo Hendrik Kurniawan, Kiichiro Kagawa. " Food powder analysis by using transversely excited atmospheric CO laser-induced plasma spectroscopy ", Journal of Physics: Conference Series, 2015	1 %
	Publication	

Exclude quotes Off
Exclude bibliography On

Exclude matches Off

A Capacitive Model of Water Salinity Wireless

GRADEMARK REPORT

FINAL GRADE

/0

GENERAL COMMENTS

Instructor

PAGE 1

PAGE 2

PAGE 3

PAGE 4

PAGE 5
