

PAPER • OPEN ACCESS

The biodegester flow distribution control system using pressure sensor MPX5700AP

To cite this article: A N D Mufidah *et al* 2019 *J. Phys.: Conf. Ser.* **1217** 012038

View the [article online](#) for updates and enhancements.



IOP | ebooks™

Bringing you innovative digital publishing with leading voices to create your essential collection of books in STEM research.

Start exploring the [collection](#) - download the first chapter of every title for free.

The biodegester flow distribution control system using pressure sensor MPX5700AP

A N D Mufidah, A Setyawan, I Gunadi and J E Suseno

Department of Physics, Faculty of Science and Mathematics, Diponegoro University
Jl. Prof. Soedharto, SH, Tembalang, Semarang 50275, Indonesia
E-mail: jatmikoendrosuseno@undip.ac.id

Abstract. One of the renewable alternative energy and has the potential to be developed is biogas energy. However, in its development there are still some obstacles, one of which is leakage on digester. This leakage is caused by excess gas pressure inside the digester, so the excess gas that should be used is wasted. In addition leaks on the digester can also cause air pollution and global warming. It is therefore necessary to design an effective by adding a controller as a pressure regulator of the biogas flow distribution. The MPX5700AP pressure sensor is installed to measure the pressure of the gas inside the digester. Excess gas in the next digester is flowed and accommodated in the container tube. Based on the research that has been done, can be produced an effective digester. With the automatic pressure control, the biogas distribution process becomes more optimal so as to minimize the exhaust gas from the digester.

1. Introduction

The usage of the automatic control system at industry, recently, are very required. There is caused the control system has more advantages compared with the conventional system. They are speed, accuracy, and less worker [5].

One of its applications is the gas pressure controlling in the biogas distribution system. The gas pressure in a digester (biogas processing tube) must be controlled to avoid the gas leak, which can be dangerous. Sutarno (2000) reasearch the gas distribution using water vapor whic made from plastic bottle for the gas pressure controlling. There is meant for easier steam from condentation result down and inlet in the bottle. The remain water in the system can pressure biogas pipeline and reduce heat level. However, there are gas lack in a digester because the performance of water vapor is less effective [7].

As statement above, we developed the automatic control which can control the gas pressure. The control system used ON-OFF control method which located in digester in order to operate easily also to avoid gas excess which can be lack at digester.

2. Theory

2.1. Control System

The control system is system which has one or some equipment and its function is to control other interconnected systems. In an industry, all process variables, such as power, temperature and flow rate,



have to be monitored real time. If these process variables are not suitable with that be desired, then the control system can control these processes, so the system can work again. The application examples of control system

2.2. On-Off Controller

In the Off-control system, the control signal only has two certain positions, namely on and off. In essence, the controller is a switch that is activated by an error signal and only supplies the On-Off correction signal. The controller output has only two possible values, which are equivalent to the on and off conditions. The On-Off control is a simple and inexpensive control mode, and is often used, where oscillations can be reduced until the level received. An illustration of the On-Off controller can be explained in Figure 1.

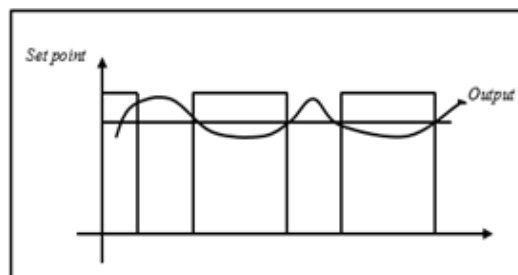

Figure 1. Illustration of on-off control signal (www.reocities.com/al_dodi/kp3.pdf)

The disadvantage of this On-Off controller is if the signal output oscillates around the set point (the desired state) will cause the actuator work hard to reach on-off condition with a high frequency. This will cause the controller to be damaged quickly and consume energy. To overcome this, it is made a band at the setpoint [6]. The illustration is shown in Figure 2.

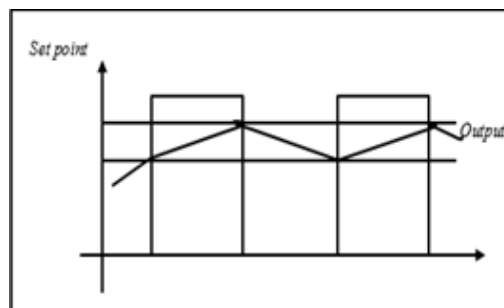

Figure 2. Illustration of band at setpoint in On-Off controller (www.reocities.com/al_dodi/kp3.pdf).

The control signal will be off when the output touches the upper limit and will be on again when touching the lower limit. The band of this setpoint is also called the differential gap. With adjusting the differential gap, the on-off frequency can be reduced but the disadvantage is a decrease in accuracy of the setpoint [6]. Examples of control systems are used in factories, buildings and in nuclear power plants [4].

2.3. Pressure Sensor MPX5700AP

The pressure sensor MPX5700AP manufactured by Motorola. This sensor has been equipped with a signal conditioning circuit and a calibrator temperature which makes this sensor stable against temperature changes. The working principle of the MPX5700AP pressure sensor based on piezoresistive effects. The piezo effect is the effect produced by a material because deformation. Piezoresistive refers to changes in material resistance values due to deformation after obtaining force or pressure. This MPX5700AP pressure sensor has the ability to measure the pressure level with a pressure range of 15 kPa - 700 kPa or 0-101.5 Psi and produces an analog output of 0.2 - 4.7 Vdc. The block diagram of pressure sensor MPX5700 can be seen in Figure 3 [3].

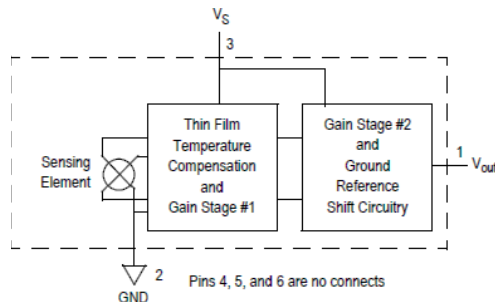

Figure 3. The block diagram of pressure sensor MPX5700 (Datasheet MPX5700 series).

3. Design and Implementation

The complete design of the distribution of biogas flow from digester is as follows:

- Using the on-off controller that is applied to the Arduino Uno to regulate the gas in the digester.
- Using the MPX5700AP sensor to measure gas pressure in the digester.
- Using a solenoid valve with a DC 12V power source as a valve that drains gas from the digester.
- Using the Songle SRD relay as a switch to activate the solenoid valve.
- Gas storage tube in the form of a modified vehicle tire. The block diagrams design of system is shown in Figure 4.

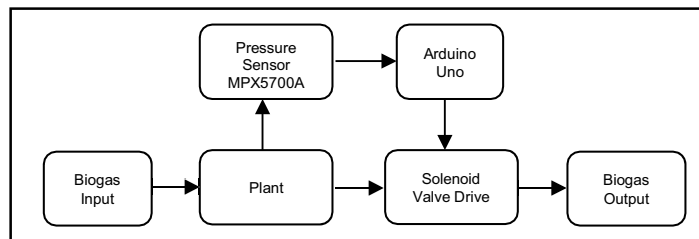

Figure 4. The block diagram of control system

3.1. Design of hardware

The design of hardware includes the design of miniature biogas digester as a place to test the system and control made from modified vehicle tires with the addition of a pressure sensor circuit, a solenoid valve driver, and a biogas storage tube.

1. MPX5700AP Sensor Series

The pressure sensor MPX5700AP serves to determine the amount of gas pressure in the digester. The sensor is connected to the A0 pin Arduino for serial communication. A0 pin is an analog pin on Arduino that receives the measurement results made by the sensor. The output of the sensor is in the form of a voltage that is translated by the microcontroller in 10 bits with a calculation like the following.

$$ADC = \frac{V_{IN} \times 1024}{V_{Ref}} \quad (1)$$

with ADC = Input conversion results

V_{IN} = Input voltage

V_{Reff} = Reference voltage Solenoid valve driver circuit

The solenoid valve driver circuit functions to activate the solenoid valve by providing a DC 12V power source on the solenoid valve. The circuit is connected with pin 13 on Arduino. The microcontroller will issue a voltage of around 5V on the intended I / O port, when the gas pressure in the digester is excessive. This voltage will trigger the driver to move the relay coil so that it connects the solenoid valve with a 12V DC power source.

The relay used in the design is the SRD relay single. This relay has a coil resistance of 70Ω for a working voltage of 5V. The solenoid valve driver circuit is shown in Figure 5.

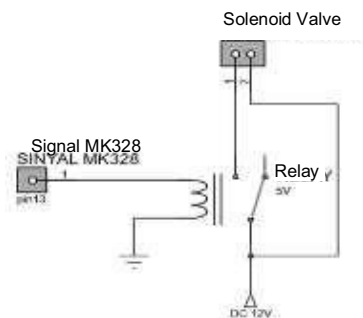

Figure 5. Solenoid valve driver circuit

3.2 Design of Software

Software design aims to regulate the work order of the system so that the system is able to perform its functions properly. The design of the control system for the distribution of biogas flow from the digester using the MPX5700AP pressure sensor generally includes reading and converting the MPX5700AP sensor output signal and controlling the gas pressure in the digester.

The MPX5700AP sensor will read the gas pressure in the digester. Sensor readings in the form of an analog signal will be sent to the Arduino ADC PIN to be converted and read by the microcontroller. If the gas pressure in the digester has reached the predetermined limit (setpoint) then the microcontroller will send high logic to the relay which causes the relay to be active and connect the DC 12 V power source with the solenoid valve, so that the solenoid valve opens and the gas from the digester can flow into the tube container. On the contrary, gas flows out into the container until the gas pressure in the digester reaches the lower limit (setpoint) that has been determined so that arduino sends low logic to the relay which causes the relay to be inactive. The inactivity of the relay causes a disconnection between the DC 12V power source and the solenoid valve, so that the solenoid valve is closed. The solenoid valve will close until the gas pressure in the digester reaches the upper limit (setpoint) again. The main algorithm system is shown in Figure 6 below.

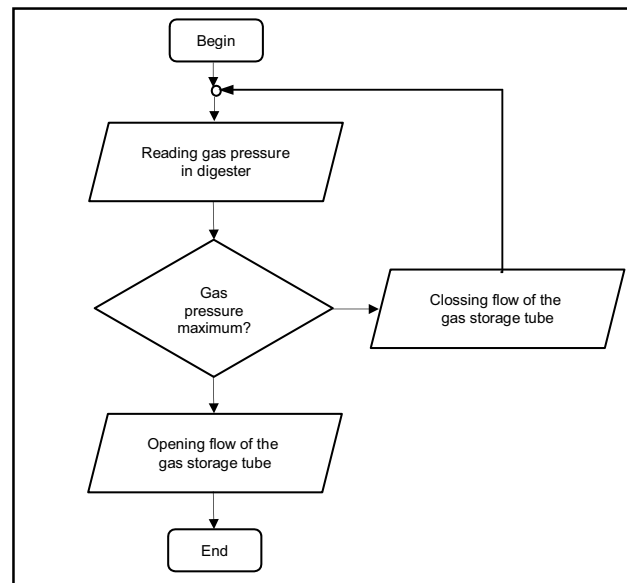

Figure 6. The main algorithm

The limit (setpoint) is determined by considering the ability of the digester tube to hold gas. From the observations, it is known that the maximum ability of a digester to store gas is when the sensor output voltage is 880 mV or 21.17 kPa for the upper limit. For the lower limit is determined based on the desired minimum pressure so that the gas remains in the digester. From the observation, it is known that the gas in the digester can flow to the biogas storage tube until when the desired sensor output voltage is 830 mV or worth 12.78 kPa.

4. Testing and Analysis

This system testing is intended to determine whether the tools that have been made function properly and in accordance with the design. Testing on this system includes testing each block and testing as a whole. The testing of each block is done to find the location of the error and facilitate the analysis of the system if the tool does not work in accordance with the design.

4.1. Testing MPX5700AP Pressure Sensor Series

Testing the pressure sensor circuit MPX5700AP aims to determine the level of accuracy of the sensor. Where the pressure value can be known by looking at the measured pressure value of the sensor. The equipment needed to do the testing are: 5 V DC power source, MPX5700AP pressure sensor, barometer, and Arduino uno. The test results by MPX5700AP pressure sensor are shown in table 1.

Table 1. Test results of the MPX5700AP sensor circuit

Barometer		Sensor		Ideal	Error (%)
Pressure (Psi)	Pressure (kPa)	Pressure (kPa)	V _{out} (volt)	V _{out} (volt)	
1	6.90	4.47	0.977	0.989	1.22
2	13.79	12.06	1.025	1.033	0.71
3	20.69	18.14	1.064	1.077	1.16
4	27.59	29.53	1.138	1.121	1.49
5	34.48	38.64	1.196	1.165	2.67
6	41.38	42.44	1.221	1.209	0.94
7	48.28	50.04	1.270	1.253	1.28
8	55.17	53.83	1.294	1.298	0.28
9	62.07	61.43	1.343	1.342	0.08
10	68.97	69.02	1.392	1.386	0.41
<u>Average error</u>					<u>1.02</u>

From the data in table 1, it can also be seen that the average error is 1.02%. There is a difference in value between calculations and measurements due to the component tolerance used, and the parallax error (error) of barometer reading.

4.2. Solenoid Valve Driver Circuit Testing

Testing of the solenoid valve driver circuit aims to determine the performance of the relay in activating the solenoid valve. The equipment needed to do the testing are: 12 V DC and 5 V DC power source, relay, Arduino Uno board, solenoid valve driver.

As a result of the following tests, when the power source is activated, the Arduino PIN 13 releases a voltage of $\pm 5V$. This voltage can activate the relay. The active relay will connect a DC 12V power source with a solenoid valve driver which means activating the solenoid valve. Solenoid valve driver testing is done by activating and deactivating the relay with a delay of 5 seconds. Obtain the solenoid valve driver to open and close alternately for 5 seconds. Thus, it can be concluded that the solenoid valve driver circuit can work well.

4.3. Overall System Testing

Overall system testing is done to determine the overall performance of the system. In this test what needs to be observed is the gas pressure in the digester. The equipment needed to do the testing are: DC 12V and DC 5V power source, MPX5700AP pressure sensor, arduino uno, and solenoid valve driver. From the testing of this whole system, it is seen that all systems are running well. After the gas pressure in the digester reaches the maximum limit, the microcontroller will send a low logic on the Arduino 13 pin which activates the relay. The relay is active resulting in a solenoid valve connected to a DC 12V voltage source, so that the solenoid valve opens, and the gas is flowed from the digester to the storage tube until the minimum gas pressure is desired in the digester. When the gas pressure in the digester has reached the minimum limit, the solenoid valve closes again so that the gas from the digester cannot flow into the reservoir. And, so on that the relay will be on-off automatically based on the results of measuring the gas pressure in the digester. The results of the gas pressure measurement and control action are displayed on a 16 x 2 LCD, so that there is clear information about the system performance that has been made. To connect the LCD to the system is to connect the A4 and A5 pins on the Arduino uno with the I2C module connected to the LCD, and program it on Arduino. The power needed to turn on the LCD is DC 5 V. The following data from the overall system testing results are shown in table 2.

Table 2. Data on overall system testing results

Gas pressuree measured			Time (s)	Actuator
ADC	V _{out} (volt)	Pressure (kPa)		
166	0.81	15.00	0	OFF
180	0.88	25.73	116	ON
170	0.83	18.13	25	OFF
180	0.88	25.73	40	ON
170	0.83	18.13	20	OFF
180	0.88	25.73	38	ON
170	0.83	18.13	19	OFF
180	0.88	25.73	40	ON
170	0.83	18.13	19	OFF

4.4. Control System Analysis

In this analysis, the average pressure increase is calculated based on the control action. The data taken is based on the controller reading time on the LCD every time it reaches the setpoint, the highest pressure is 25.73 kPa and the lowest pressure is 18.13 kPa. The system requires charging time of about 116 seconds to fill the digester from the start of the system until the pressure in the digester reaches the maximum and takes about 20 seconds to remove the gas from the digester into the storage tube until it reaches the lower limit (setpoint). The following are graphs of data collection and average time-based increases in the biogas flow distribution control system

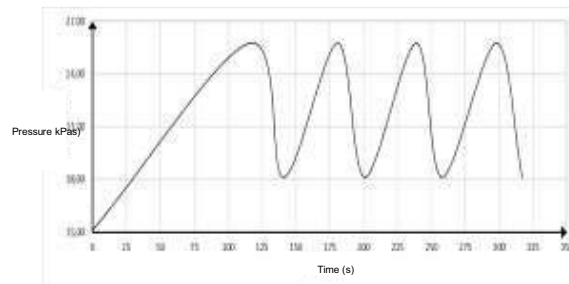

Figure 7. Signal response of control system

When the gas pressure in the digester reaches the maximum limit, the amount of pressure measured by the sensor will be sent to Arduino. The pressure will be converted by the ATmega328 Microcontroller on Arduino. Conversion is done by converting the analog signal from the sensor to a digital signal which will then be compared to the setpoint. If the value exceeds the maximum pressure limit that is set then the Arduino will activate the relay which causes the solenoid valve to be connected to the DC 12 V power source, then the solenoid valve opens and the gas flows into the storage tube. If the value below the minimum pressure limit is specified then Arduino will deactivate the relay which causes the solenoid valve to be disconnected with a DC 12V power source, then the solenoid valve closes.

5. Conclusion

A control system for the distribution of biogas flow from the digester has been made using an On-Off controller to keep condition of the gas pressure. Digester with control can accommodate gas up to 25.73 kPa with an error of 1.02%.

Acknowledgements

This research was supported by research grant of Faculty of Science and Mathematics, Universitas Diponegoro.

References

- [1] Ali, M. 2012. *Sistem Kendali Terdistribusi "Konsep Dasar Sistem Kontrol"*, Pendidikan Teknik Elektro, Fakultas Teknik Universitas Negeri Yogyakarta.
- [2] Erinofardi, Supardi, N. I., Redi, 2012, Penggunaan PLC dalam Pengontrolan Temperatur, Simulasi pada Prototype Ruangan. *Jurnal Mekanikal* **3** (2) 2086-3403.
- [3] Freescale. 2012. Freescale Semiconductor, Datasheet: Technical Data. www.freescale.com.
- [4] Diunduh pada hari Senin, 11 September 2017 pukul 15.30 WIB.
- [5] Ogata, Katsuhiko.,1995, *Teknik Kontrol Otomatik (Sistem Pengaturan) jilid 1*, Erlangga, Jakarta.

- [6] Ridwan Arif, Hendik Eko H.S., Irianto, 2009, Rancang Bangun Sistem Pengaturan Tekanan Pompa Air Menggunakan Sistem Kontrol Logika Fuzzy Sub Judul: Kontroler dan Software, *Skripsi*, Fakultas Teknik Institut Teknologi Sepuluh Nopember, Surabaya.
- [7] Setyobudi, A.D. dan Indra Kurniawan, 1998. *Kontroler On-Off*, Laporan Kerja Praktek di Politeknik Manufaktur Bandung, Institut Teknologi Bandung, Bandung.
- [8] Sutarno, 2000, Potensi Limbah Kotoran Sapi Sebagai Sumber Energi Alternatif, *J. Intuisi Teknologi dan Seni*, ISSN: 1978-2497.