

Design and Prototyping of an Electric City Car for Two Passengers

Munadi

*Mechanical Engineering Department
Universitas Diponegoro
Semarang, Indonesia
National Center for Sustainable
Transportation Technology, Indonesia
munadi@lecturer.undip.ac.id*

Ismoyo Haryanto

*Mechanical Engineering Department
Universitas Diponegoro
Semarang, Indonesia
National Center for Sustainable Transportation
Technology, Indonesia
ismoyo2001@yahoo.de*

Mochammad Ariyanto

*Mechanical Engineering Department
Universitas Diponegoro
Semarang, Indonesia
National Center for Sustainable
Transportation Technology, Indonesia
mochammad_ariyanto@ft.undip.ac.id*

Joga Dharma Setiawan

*Mechanical Engineering Department
Universitas Diponegoro
Semarang, Indonesia
National Center for Sustainable
Transportation Technology, Indonesia
joga.setiawan@ft.undip.ac.id*

Urip Kurniawan

*Mechanical Engineering Department
Universitas Diponegoro
Semarang, Indonesia
uripkurniawan@ymail.com*

M. Beny Dwifa

*Mechanical Engineering Department
Universitas Diponegoro
Semarang, Indonesia
dwishastra.bhakti@gmail.com*

Abstract—Land transport has contributed to air pollution that occurs. This forced the car manufacturers to improve the quality of their products in order to pass the exhaust emissions standards. In addition to exhaust emissions, the limited source of vehicle fuel energy is the reason some researchers develop electric cars. This article conveys the results of research on prototyping an electric city car for two passengers with wheel hub motor type configuration as our research pilot project related to electric cars. The data acquisition aids made are equipped with a LabVIEW-based human-machine interface that makes it easier for researchers to monitor the consumption of electric cars in real-time. Based on the design process, manufacture, until testing, the value of drag coefficient is 0.47; testing for curb-weight is 510 kg; maximum speed is 75.3 km/hour; the maximum power is 3.03 kW at 602 rpm wheel speed; and the maximum torque is 50.8 Nm at a wheel speed of 516 rpm. For the state of charge, this prototype of an electric city car is capable of traveling up to 42.4 km from 100% to 20% SOC.

Keywords— *electric city car, wheel hub motor, human machine interface*

I. INTRODUCTION

Air pollution has become one of the environmental problems at this time. The majority of air pollution caused by human activity has been the biggest contributor. According to the World Resources Institute report as reported by the Daily Mail (3/10/2014), Indonesia ranks sixth as the largest carbon dioxide emitting country in the world with a total of 2.05 billion tons. This is corroborated by the increasing global CO₂ emission data in parts of the world [1].

With the increase in public awareness of a healthy environment, it is encouraging the Indonesian state to raise vehicle emissions standards. Initially in 2013 implemented Euro III, and now it has risen to Euro IV standards. This forces vehicle manufacturers to be able to produce vehicles that have better levels of exhaust emissions. These

opportunities make electric car research increase from year to year.

Research on electric cars has become an interesting topic because the results of this study are very useful for the community, especially in suppressing global warming as well as the substitution of energy sources derived from fossils where the number is increasingly limited [2]. So, the development of electric cars into one weapon in overcoming transportation problems [3]. Because the topic of electric car research is still new and the results have not been enjoyed by many people, then related to marketing the results of electric car research there must be market rules and standards [4]. Some of the development of electric car research has reached the stage of optimizing the energy consumption of electric cars. Several methods have been submitted by researchers, including those given in [4-8]. In addition, an energy management system research was also developed [9].

In this research, we will make a prototype of a two-passenger electric car. The prototype of the electric car will be designed using two motor hubs (Kelly motor hub) and two electronic speed controllers (Kelly Controller). Software used for simulation is CAD software and fluid software. CAD software is used to design electric cars. File from CAD software is imported in the fluid software to simulate the optimal coefficient of electric car body drag coefficient. This simulation is done as a solution to reduce costs when compared to using wind tunnel testing. The prototype electric car testing is carried out in the laboratory and on the track in campus.

II. ELECTRIC CITY CAR DESIGN

A. The First Design of Electric City Car

The prototype of this electric car is designed in the type of city car with two people with wheel hub motors, which applies the monocoque type. Monocoque is a framework that is formed and become a unit with the vehicle body [10].

The monocoque type is chosen because it is most possible for the manufacturing process. The prototype design of this electric car takes into account the very limited capability of the manufacturing process, so we declare it as the first edition. The body shape and dimensions as the first design of this electric car are shown in Fig. 1.

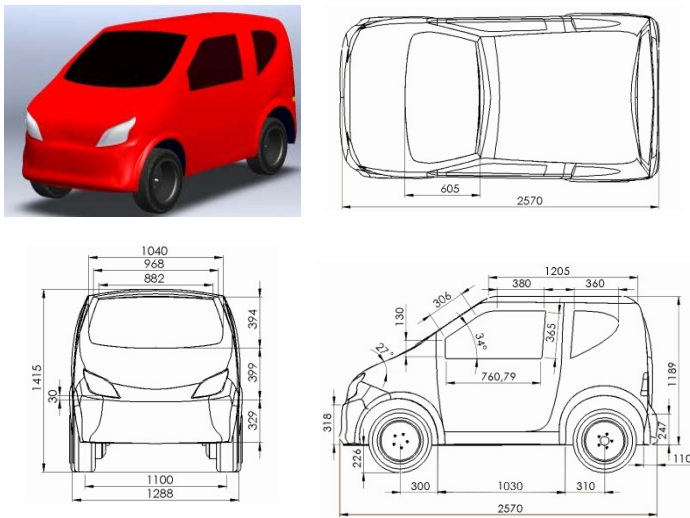

Fig. 1. The first design of an electric city car

After the CAD design of the electric car was successfully designed, a simulation of the drag coefficient (Cd) of the electric car was done using software. Drag coefficient values of city car types in general are between 0.30 - 0.34 [11]. The simulation is based on a journal reference that has been validated in [12] where the settings used to produce simulation results are close to the experimental results, then three variations of the turbulent model are shown in Table 1. The parameters used include density = 1.22 kg/m³; viscosity = 1.78 x 10⁻⁵ kg/ms; inlet velocity = 40 m/s; inlet turbulence intensity = 0.57 %; and hydraulic inlet diameter = 0.33 m.

TABLE I. COMPARISON OF DRAG COEFFICIENT

No	Turbulent model	Cd	Drag reduction
1	Experiment	0,285	-
2	k - ω standard	0,289	0,004
3	k - ω SST	0,315	0,030
4	Spallart almaras	0,340	0,055

Table 1 shows the software settings that produce the smallest error when using the k- ω standard turbulent model, where the difference between simulation results with experiments is 1.4 %. Furthermore, the turbulent model used in this simulation is using the k- ω standard. In the simulation, the size of the wind tunnel used based on the reference has a length of 6L, the height of the tunnel is the height of the car plus 2.5 m, the width of the tunnel is the width of the car plus 2 m on each side with details as shown in Fig. 2 (a). To get better results, a meshing density of 9 m x 2.6 m x 3 m was carried out in the previous meshing box with detailed position as shown in Fig. 2 (b).

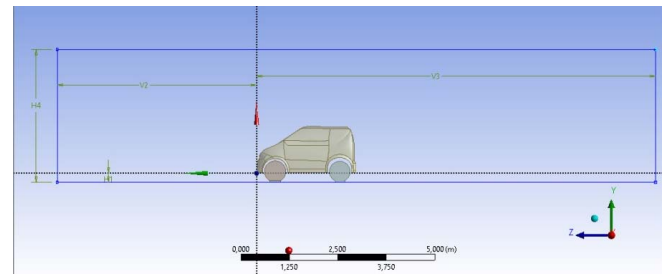

(a)

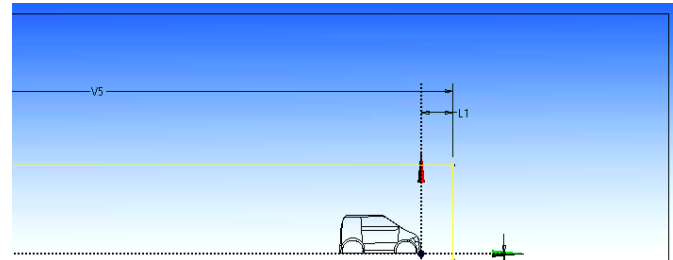

Fig. 2. The size of the wind tunnel (a) the size of the outer meshing box (b) the size of the meshing sealing box

Varying the size of the meshing (sizing) in each box aims to get a good statistical meshing. Based on information in the software, the maximum statistical value on acceptable skewness mesh is below 0.94. In order to obtain more valid simulation results, the process to obtain mesh independence is carried out, namely by performing a number of simulations with the same settings in the software but varying the number of different meshes so that the simulation results obtained are close to each other. That value is taken as a simulation result.

The simulation is done with the assumption that the electric car will go with a speed of 60 km / h relative to the wind speed, this is because the average target of using an electric car that is designed is 60 km / hour. In the initial design only two simulations were performed with two variations of the number of mesh. Because of these results it can be concluded that the Cd value is still greater than 0.5, it is necessary to design improvements. The amount of skewness and simulation results are shown in Table 2.

TABLE II. DRAG COEFFICIENT FOR THE FIRST DESIGN

Total Elements	Max. Skewness	Average Skewness	Cd
1242822	0,91724	0,22033	0,56975
2120289	0,89597	0,21426	0,57550

B. The Second Design of Electric City Car

The target of the electric car design that we make is to have a drag coefficient value below 0.5. Therefore, it is necessary to improve the design which includes: adding air dam, reducing the angle of the front of the car to the horizontal axis, forming a fillet on the edge of the front of the car, reducing the angle of the windshield against the horizontal axis, enlarging the angle of the rear glass to the vertical axis, reducing frontal area of the car and streamline the upper body. Fig. 3 on the left shows the first design and the right shows the second design after an improved electric car design.

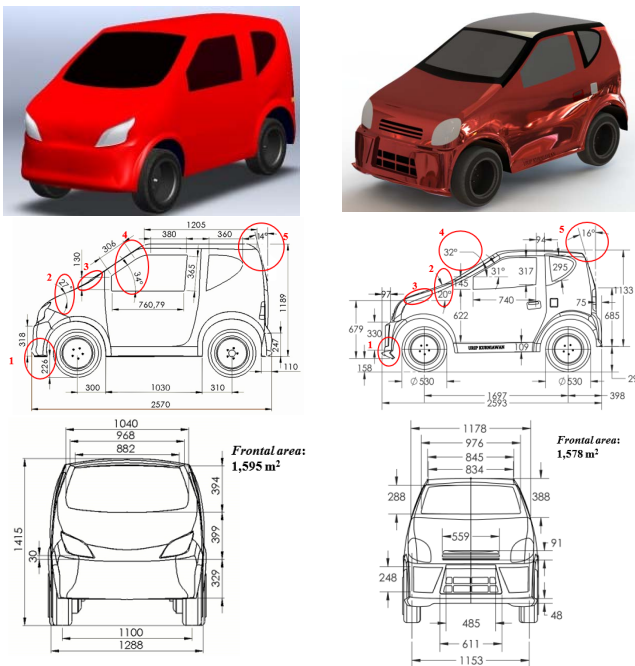
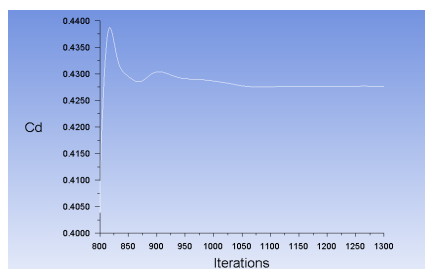

Fig. 3. The second design of an electric city car

After the design improvement is shown as the second design, the simulation is carried out again. In this second design a simulation with five variations of the number of mesh is performed. The amount of skewness and simulation results are shown in Table 3. Based on several variations of the number of mesh, the coefficient of drag is obtained at a stable value of 0.47, which is indicated by the difference in the value of Cd in the next simulation is below 1%. So, it was concluded that the drag coefficient of design improvement was 0.47 as shown in Figure 4 (a). As for Figure 4 (b) shows the distribution of pressure vectors that illustrate the pressure difference in some parts of the body of an electric car. The highest pressure is indicated by the red color which is located on the front of the car body with a maximum pressure reaching 696 Pa, while the lowest pressure is indicated by the blue color -2630 Pa. This design is used for the electric car manufacturing process.

TABLE III. DRAG COEFFICIENT FOR THE SECOND DESIGN

Total Element	Max Skewness	Average Skewness	Cd	% Cd difference
1311021	0,85571	1311021	0,49810	1,94 %
1519063	0,85577	0,22489	0,48841	1,78 %
2154165	0,85567	0,21905	0,47970	0,40%
2628085	0,8557	0,21687	0,47780	0,59%
2660602	0,8557	0,21671	0,47498	-



(a)

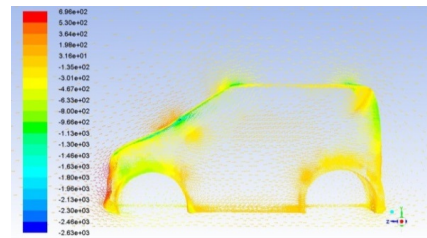

(b)

Fig. 4. (a) Drag coefficient graph; (b) Vector pressure of the fluid

III. HARDWARE AND SOFTWARE

The prototype of this electric car consists of hardware (mechanical and electrical) components and software. The main components of mechanical and electrical hardware include actuators in the form of BLDC motors, controllers, batteries, charger units, microcontrollers and several sensors. While the software component is a data acquisition system that uses LabVIEW software.

A. Mechanical and Electrical Component

BLDC motors function as converters of electrical energy from batteries into motion energy used to drive vehicles [13, 14]. This motorbike also has a regenerative brake system feature that is able to convert some of the motion energy in the car into electrical energy again when braking, then the electricity is saved to the battery [15]. This motor has a braking function but not as a main braking tool but only as a helper, so this type of motor was chosen because its characteristics are most suitable for use in electric cars. The location of the installation of the hub motor is attached to the wheels and co-turns with the wheels when the vehicle is moving. By considering the performance target of the electric car to be achieved is able to go with a speed (V) of 60 km/h, with a wheel diameter (D) of 51 cm, then the value ω of 624.45 rpm is obtained. Then a hub motor with a specifications of 72V 7KW with a weight of 60 pounds and a maximum speed of 1300 rpm was chosen. The type used is the hub motor type so that it does not require transmission or differential. This type has a regenerative brake system and uses a hall sensor.

The controller is a component that functions to move the BLDC motor based on the signal from the hall sensor and with reference to the program from the default software after user settings. The controller applied to this electric car is KBL72401E. This controller was chosen because it is a pair of BLDC motors used and has several advantages in terms of features, one of which is that it allows the regenerative brake system. The controller is placed at the back of the car precisely behind the passenger seat. A total of two, each to control one BLDC motor. The placement of the controller at the rear, is intended so that the distribution of electric current to the BLDC motor which is also located at the rear wheels will be better and more efficient. In addition to this, the ease of testing and setting is a consideration for the positioning of the controller.

In the type of pure electric vehicle, the battery is the only place for storing energy to drive the car, namely electrical energy. The battery used is Dry Battery / MF (Maintenance Free) Calcium Battery, which is placed on the front hood of the car with a total of 6 pieces and arranged in series. Battery selection is based on the capacity and current that

can be removed by the battery. The maximum current that can be discharged by the battery at a temperature of -180 C is 600 A is enough to provide supply to electric motors that require large currents. Besides other considerations, namely from the dimensions of the battery. Because the capacity of this type of battery is directly proportional to the dimensions and mass of the battery, the use of a large capacity battery will also affect the greater dimensions and mass of the battery.

Another important component is the charger unit. The function of the charger unit is to recharge the car battery with power supply from a 220 VAC source. The charger specification used is the F7201 type, with an input voltage of 220 V AC . The resulting output is 72 V with a charging current of 10 A . This type of charger is used because it is able to recharge to six batteries at once. The unit charger input socket is placed on the left side of the car close to the rear wheels while the adapter is placed on the front hood close to the battery position. Another important component is the microcontroller. The function of the microcontroller in this study is as a data acquisition tool. The research data recorded by the sensor is then distributed to the microcontroller for processing and then displayed on a monitor, usually the data is presented in graphical form. The microcontroller used is NI myRIO-1900. The wiring diagram for the hardware component is shown in Fig. 5 and the layout of the components in the electric car prototype is shown in Fig. 6.

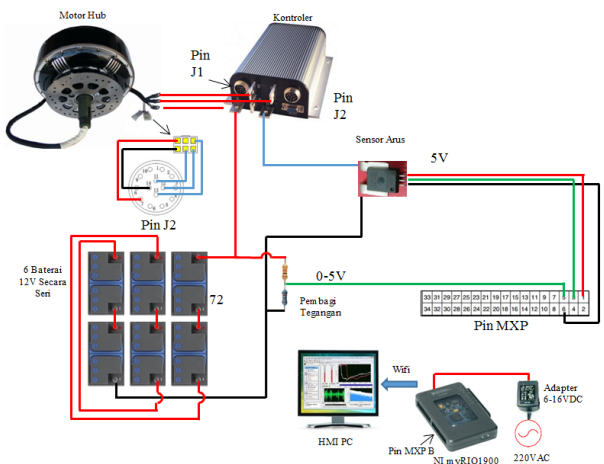
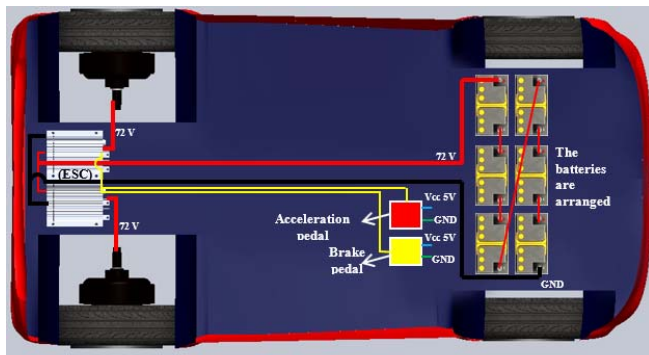

Fig. 5. Wiring diagram for component of the electric car



- Output cable from pin Vcc 5 volt ESC
- Cable pin ground ESC (GND)
- Analog data cable 5 volt from pedal
- Red cable plus (positive terminal) = 72 volt
- Black cable (negative terminal) = GND

Fig. 6. Electrical component circuit layout for electric cars

B. Data Acquisition System

Electronic data acquisition (DAQ) system that uses several components is useful in helping to obtain and analyze data. For maximum DAQ performance, NI myRIO-1900 components and some sensors such as external hall sensors are used. For software using LabVIEW, so that human machine interface programming can be done to facilitate the operation of the data acquisition tool. The HMI front panel is shown in Figure 7 and the block diagram is shown in Figure 8. The program starts with the input of a voltage signal. Here there are three input signals, each of which is described as voltage, current and wheel rotation. Each is entered in the Analog Input (AI).

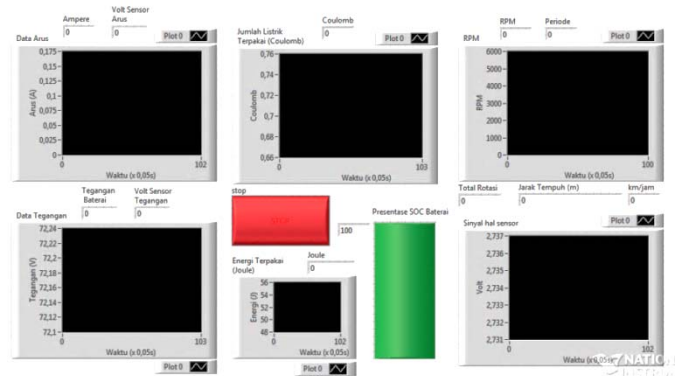

Fig. 7. Display of the HMI front panel

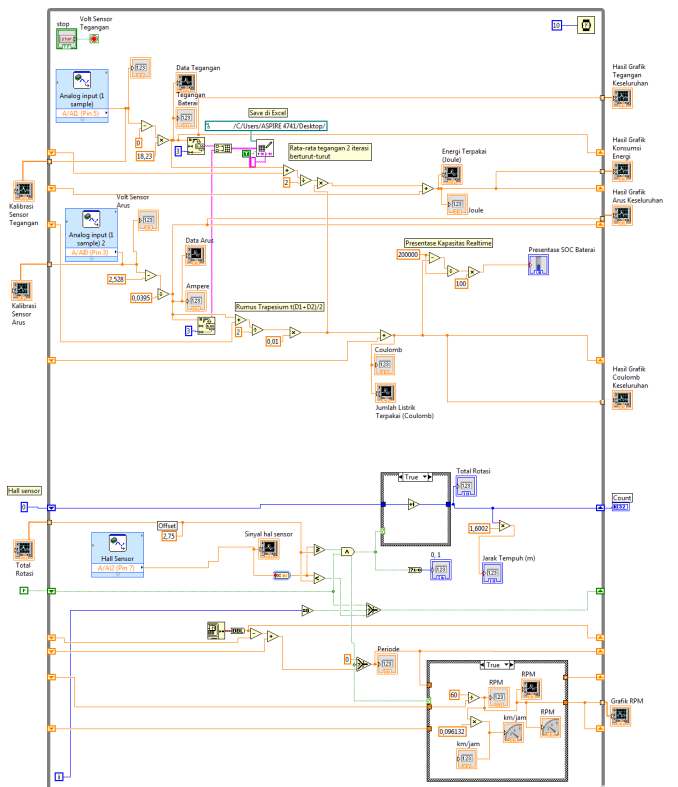

Fig. 8. Block diagram of LabVIEW for HMI

IV. DISCUSSION AND RESULT

A. Curb Weight Measurement

Curb weight or mass of the vehicle in an empty condition (without passengers and transport loads) is measured using a portable load tester. Measurements were

made on each wheel with the condition of the car really flat, so that it can determine the load bearing on each wheel. The instrument used to measure this curb weight is the Whell and Axle Weigher CAS Corporation RW 2601P series. This tool uses a strain gauge sensor to detect deflection due to the load on it which is then converted as mass output on the tool display. The curb weight measurement process is shown in Figure 9. After measuring using a load tester the total weight is 510 kg. With details of 150 kg right front wheel, 150 kg left front wheel, 100 kg right rear wheel, and 110 kg left rear wheel.



Fig. 9. The curb weight measurement

B. Maximum Speed Testing

In this electric car research, the process of measuring the maximum speed of the car was not carried out on the track as per the UNECE68 testing standard but was approached using a dynamometer and on-campus track. The maximum speed testing process and the results are shown in Fig. 10. The speed obtained is 75.3 km / hour.



Fig. 10. Maximum speed testing and results

C. Maximum Torque and Power Testing

Testing for the maximum power and torque of an electric car is done using the Dastek Dynamometers brand dynamometer chassis. The testing step begins with calibration of the crankshaft angular velocity with the electric motor to be tested. Calibration is done by running the car on the dynamometer to a certain speed so that the data that appears is sufficient to be taken as a calibration factor. After knowing the times factor for calibration, the engine is run three times. After doing three turns, the results are seen in the form of maximum power and maximum torque of electric cars.

The dynamometer used requires calibration of the crankshaft rotation at 3000 rpm. This is due to the electric car there is no crankshaft rotation. The measured speed is the angular speed of the electric motor, so calibration

requires the motor to rotate at 3000 rpm. While this is not possible because the specifications of the electric motor used can only reach 1200 rpm. The solution is to use the times factor. This test analogizes the crankshaft rotation that appears on the dynamometer monitor as the rotation of an electric motor with a certain times factor. The tool calibration setting process is shown in Fig. 11.



Fig. 11. Test calibration process, linear wheel speed display (left), power car torque and graphic display (right)

Due to the electric car tested is wheel hub type, the wheel speed is the same as the speed of the electric motor, so it can be calculated. Based on the calibration of the wheel angle speed to the times factor, the setting value is 49.5 km / h = 3000 rpm. Next the same thing is done which is tabulated in Table IV where an average factor of 0.1720 is obtained.

TABLE IV. CALCULATION OF TIMES FACTORS USED

V (km/h)	ω crankshaft calibration (rpm)	ω wheel (rpm)	Times factor
49,5	3000	515,6	0,1719
50,0	3023	520,8	0,1723
51,8	3141	539,6	0,1718
58,9	3571	613,5	0,1718
71,8	4348	747,9	0,1720
		Average	0,1720

Based on the results of testing the power and torque using a dynamometer, the maximum power is 3.03 Kw at 602 rpm, and the maximum torque is 50.8 Nm at 516 rpm. The value of the power generated is far from the motor power when no load because the burden of the car being driven is quite heavy ie 510 kg plus 180 kg of passengers. The power obtained is the power on the wheels that is directly related to the speed of the car (rotating speed of the wheel) is different from the power of the crankshaft on the internal combustion engine car which is generally higher because it is associated with high engine rotational speed but not directly related to car speed. The graph of maximum power and torque can be seen in Fig. 12.

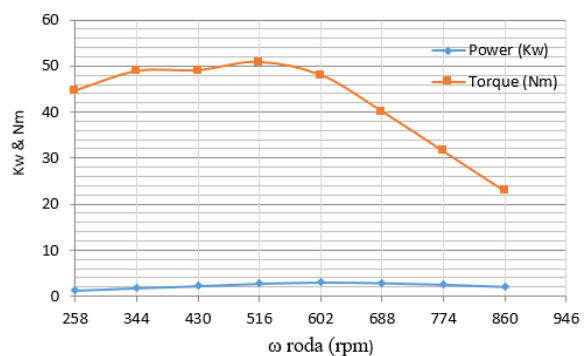

Fig. 12. Result of power and torque testing on chasis dynamometer

D. State of Charge (SOC) Testing

There are several ways that can be used to obtain SOC values, two of which are using the coulomb counting method and voltage measurement. Coulomb counting method is to calculate the electrical energy stored in batteries. Energy stored in batteries is calculated in coulombs by integrating the current with respect to the time during which the electric current flows. The amount of energy given to the cell (charging) or expelled from the cell (discharging) can be obtained by adding up the current that has been expended or put into the cell over time, so that in this way the energy capacity that has been filled and which is still empty is obtained.

In testing the SOC electric car battery is carried out with the following stages:

- Charge the battery fully with the CC / CV (constant current and constant voltage) charging method to get the battery fully charged or 100% SOC. After removing the charger, measure and record the battery voltage at 100% SOC.
- Uses battery energy by running the car (either on a track or chassis dynamometer) with a constant speed of 60 km / h, or if the car is unable to reach the constant speed it can use a smaller speed (UNECE 101 annex 8). This is done until the battery is no longer able to move the car.
- Measuring the electric current flowing, time, and the path taken during the test.
- Calculate the effective electrical energy capacity that can be used to drive a car by integrating current with time.

After the total energy is obtained, the value is used as 100 % SOC of electric car batteries, so that for other SOC conditions obtained. The process of measuring 100% SOC using the coulomb counting method can be shown in Fig. 13. Determination of a battery SOC using the coulomb counting method requires monitoring of the amount of electricity used or supplied continuously from 100 % SOC until the car cannot move. Because the electric motor used in electric cars does not allow running continuously to spend electricity on the battery, the researchers decided to combine the SOC coulomb counting method with the voltage method.



Fig. 13. SOC testing using coulomb counting method

Based on data that can be taken using data acquisition tools, it shows that the ratio of changes in voltage on the battery to the amount of electrical energy consumed when running on a dynamometer and on the track shows the same approach. Recorded for every 18 Wh of energy used by electric cars, the battery voltage drops by 0.1 volt. Using 72.3 volts as 100 % SOC and assuming 0 % SOC occurs when the total battery voltage is 60 volts (10 volts x 6 pieces), there is a range of 12.3 volts. Therefore the energy used is equal to 2214 Wh. For the maximum battery usage

standard is when the SOC is in the position of 20 % then only 80 % of energy can be used which is 1771 Wh. If the conditions of using electric cars are identical as when testing on the track, then the maximum mileage is 42.4 km. This means that this electric car can cover a maximum distance of 42.4 km from 100 % SOC to 20 % SOC.

E. Testing of Energy Consumption

Testing of energy consumption of electric cars should be done according to UNECE101 annex 7 standard which has its own guidelines in running the car on the track and with some of the track requirements as in section 3.7.2 point a-c. In testing on the track the car is run following the elementary urban cycle and extra urban cycle charts [UNECE101, 2005]. This explains that the car is operated not at a constant speed but rather there is acceleration and deceleration as is also the case on city roads in general. By using this method it is expected to be able to represent the value of the energy consumption of electric cars when used on city streets.

However, due to the absence of trajectories that meet the requirements, the energy consumption testing is carried out in two ways, namely using a dynamometer and on a trial track on campus. The test is carried out on the test track shown in Figure 14 (a) which has a length of 1.37 km for one round with a ground contour as shown in Figure 14 (b). Contour height data is also obtained from Google Earth data, although the contour characteristics are close to real conditions, but for the lowest height difference data with the highest is in fact only about 4 meters. Electric cars go as far as 2.5 rounds with or 3.4 km.

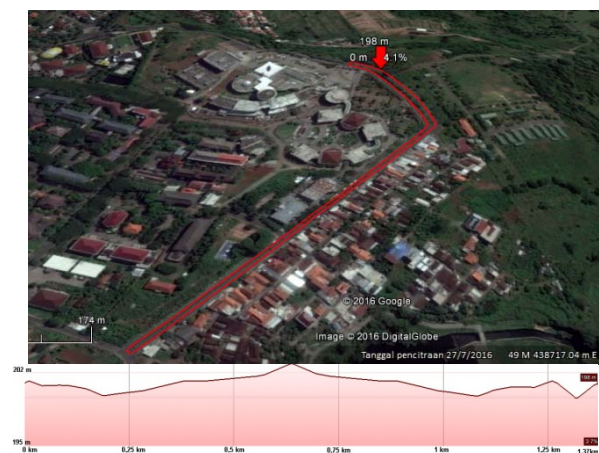

Fig. 14. The shape of the track and contour of the land



Fig. 15. Testing the energy consumption of electric cars on the test track

Based on the two test methods performed, the test results from the dynamometer and those carried on the track have a different results. For electrical energy consumption in the test above the dynamometer obtained a value of 19.7 Wh / km, while for electrical energy consumption in the test on the track obtained a value of 41.8 Wh / km. Factors that cause more electrical energy used when on the track are the variations in the acceleration and deceleration of cars that require more energy, the friction of the four wheels with the road, the misalignment factors in the direction of the right and left wheels so that it increases the friction force while driving, the difference in the slope of the road, the drag force by the air.

F. Electric Voltage Monitoring

Voltage monitoring when first tested is very important. Fig. 16 (a) shows the results of monitoring the voltage of an electric car carried over the dynamometer at a constant speed of 60 km / h for 6 minutes with an additional load on the car of 180 kg as an assumption of the weight of 2 passengers. The results of the acquisition data show the initial battery voltage value before running at 72.3 volts. At the initial start will run, the voltage drops to 53.65 volts, then rises again until awake between 66-67 volts. At the time of stopping the wheel rotation of the car (regenerative brake), there is no load done by the electric motor and instead it takes charging during braking, so that when braking takes place the voltage rises to reach 75.14 volts. At the end of this test, the voltage drops again to 71.8 volts.

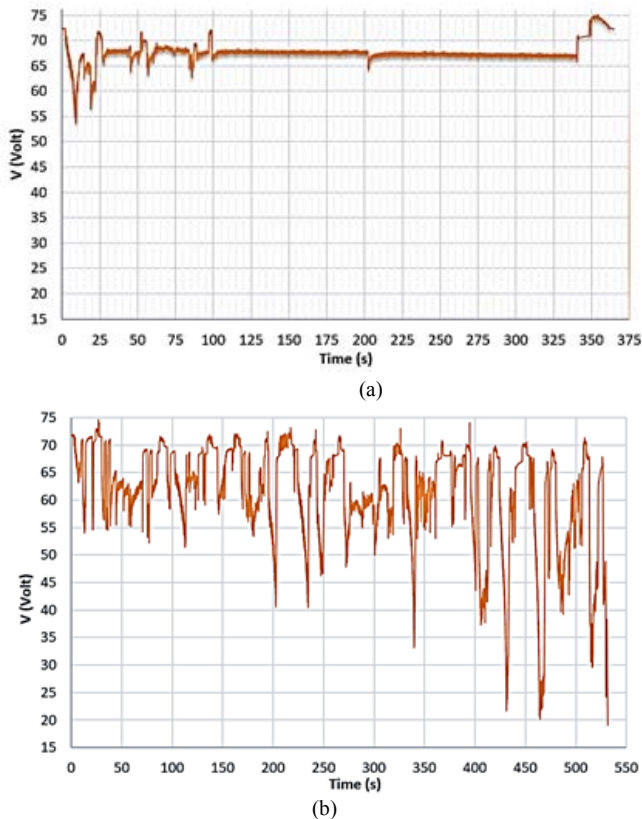

Fig. 16. Voltage data acquisition graph on battery testing (a) over the dynamometer (b) on the track

Fig. 16 (b) shows the results of testing the voltage of the electric car when testing on the track with a distance of 3.4

km and an additional load of 180 kg. The speed is maintained at 30 km / h but due to the condition of the track there are bends and speed bumps so it is not possible to drive at a constant speed so that the car drove several times with acceleration and deceleration. This also affects the results of the voltage acquisition data. The results of the acquisition data show the initial battery voltage value before running at 71.8 volts. As a result of acceleration and deceleration, the voltage data values rise and fall according to the load that must be borne by the motor. The highest voltage is achieved during the regenerative brake process which is 74.6 volts and the lowest voltage occurs at the 4th minute, amounting to 40.5 volts.

G. Electric Current Monitoring

Fig. 17 (a) shows the results of the electric car current testing carried out on the dynamometer. The results of the acquisition data show the initial value of the battery before the electric car is running close to zero. At the initial start will run the electric current rises to 62 A, then falls again to awake at a number between 13 -16 A. At the time of stopping the spinning wheel of the car using regenerative brakes, so that when the brake is pressed no load is carried out by the electric motor and instead charging occurs during braking, as a result when the braking takes place a reversal of the electric current takes place the largest value reaches 15 A into the battery. By calculating the energy from the acquisition of current and voltage data taken simultaneously (synchronous) and realtime with a sampling frequency of 100 hz the total electrical energy used is 98.37 Wh. From the magnitude of the speed and duration of testing can be obtained a distance of 5 km. So, in the above test conditions dynamometer with this speed, the energy consumption of electric cars is quite small at 19.7 Wh / km.

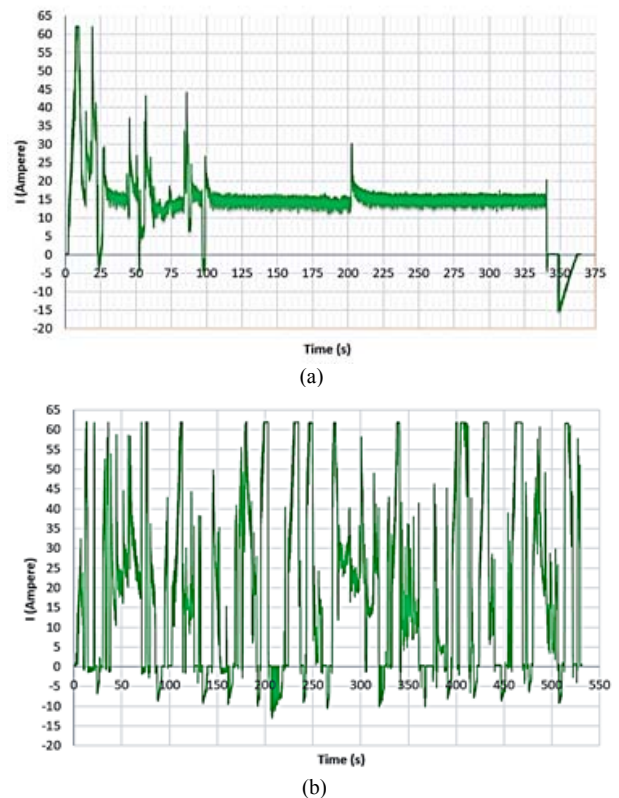

Fig. 17. Graphs of current acquisition data on the battery at the time of testing (a) using a dynamometer (b) on the track

Fig. 17 (b) shows the results of testing the electric car current when testing on the track with a distance of 3.4 km and an additional load of 180 kg. The data acquisition results show the initial battery current value before running close to zero. As a result of acceleration and deceleration, the current value goes up and down according to the load that must be borne by the motor. The highest current value that was issued was 62 A. At the time of the braking process with regenerative brakes there was a reversal of the direction of the current whose largest value reached 13 A towards the battery. By calculating current and voltage in realtime with a frequency of 100 hz, the total electrical energy used is 142.34 Wh with a distance of 3.4 km. So, in the test conditions on the track the energy consumption of electric cars reaches 41.8 Wh/km.

V. CONCLUSION

This paper presents the results of research on making a prototype two-passenger electric car. Based on the results of the design and simulation, the coefficient value of the drag body of an electric car is 0.47. The prototype specifications of the electric car produced are another curb weight value of 510 kg, the maximum speed of the electric car is 75 km / h, maximum torque is 50.8 Nm, maximum power is 17.6 Kw, energy consumption is 19.7 Wh / km (dynamometer) and 41.8 Wh / km (trajectory), the total effective energy in the battery when 100% SOC to 20% SOC is 1171 Wh so that if the conditions of using electric cars are identical as when testing on the track, then this electric car is able to travel distances of up to 42.4 km from 100% SOC to 20% SOC batteries.

ACKNOWLEDGMENT

This paper was supported by USAID through Sustainable Higher Education Research Alliances (SHERA) Program-Centre for Collaborative Research (CCR) National Center for Sustainable Transportation Technology (NCSTT).

REFERENCES

- [1] Kenneth, Holmberg, A. Erdemir, "The Impact of Tribology on Energy Use and CO₂ Emission Globally and in Combustion Engine and Electric Cars," *Tribology International*, vol. 135, pp. 389-396, July 2019.

- [2] A. Kihm, S. Trommer, "The New Car Market for Electric Vehicles and the Potential for Fuel Substitution," *Energy Policy*, vol. 72, pp. 147-157, October 2014.
- [3] W. Kempton, S.E. Letendre, "Electric Vehicles as a New Power Source for Electric Utilities," *Transportation Research Part D: Transport and Environment*, vol. 2 (3), pp. 157-175, September 1997.
- [4] S. Brown, D. Pyke, P. Steenhof, "Electric Vehicles: The Role and Importance of Standards in an Emerging Market," *Energy Policy*, vol. 38 (7), pp.3797-3806, July 2010.
- [5] M. Kolhe, S.K. Adhikari, T. Muneer, "Parked Electric Car's Cabin Heat Management using Photovoltaic Powered Ventilation System," *Applied Energy*, Vol. 233-234, pp. 403-411, January 2019.
- [6] Y. Li, Z. Zhong, K. Zhang, T. Zheng, "A Car-following Model for Electric Vehicle Traffic Flow Based on Optimal Energy Consumption," *Physica A: Statistical Mechanics and its Applications*, vol. 533, pp. 122022, November 2019.
- [7] T. Wilberforce, Z. El-Hassan, F.N. Khatib, A. Al Makky, A. Baroutaji, J.G. Carton, A.G. Olabi, "Developments of Electric Cars and Fuel Cell Hydrogen Electric Cars," *International Journal of Hydrogen Energy*, vol. 42 (40), pp. 25695-25734, October 2017.
- [8] R. Mounce, J.D. Nelson, "On the Potential for One-way Electric Vehicle Car-Sharing in Future Mobility Systems," *Transportation Research Part A: Policy and Practice*, vol. 120, pp. 17-30, February 2019.
- [9] T. Schwickart, H. Voos, J.R. Hadji-Minaglou, M. Darouach, A. Rosich, "Design and Simulation of a Real-time Implementable Energy-Efficient Model-Predictive Cruise Controller for Electric Vehicles," *Journal of the Franklin Institute*, vol. 352 (2), pp. 603-625, February 2015.
- [10] I. Krkischko, J.R. Meneghini, "Experimental Investigation and Numerical Simulation of the Flow Around an Automotive Model: Ahmed Body," 19th International Congress of Congress of Mechanical Engineering, November 5-9, 2007, Brasilia.
- [11] M. Ehsani, "Modern Electric, Hybrid Electric & Fuel Cell Vehicles, Fundamentals, Theory, and Design," CRC Press LLC: Boca Raton, 2005.
- [12] E. Guilmineau, "Computational Study of Flow Around a Simplified Car Body," *Journal of Wind Engineering and Industrial Aerodynamic*, vol. 96, pp. 1207-1217, June 2008.
- [13] A. Kapun, M. Curkovic, A. Hace, K. Jezernik, "Identifying Dynamic Model Parameters of a BLDC Motor, Simulation Modelling Practice and Theory, vol. 16 (9), pp. 1254-1265, October 2008.
- [14] A. Purwadi, J. Dozeno, N. Heryana, "Testing Performance of 10 kW BLDC Motor and LiFePO₄ Battery on ITB-1 Electric Car Prototype," *Procedia Technology*, vol. 11, pp. 1074-1082, 2013.
- [15] S. Geraee, H.M. Bagherpoor, M. Shafiei, M. Valizadeh, F. Montazeri, M.R. Feyzi, "Regenerative Braking of Electric Vehicle using a Modified Direct Torque Control and Adaptive Control Theory," *Computers & Electrical Engineering*, vol. 69, pp. 85-97, July 2018.